

MP3MOD4 – MP3 Development Module (Fourth Generation)

The MP3MOD4 shown in diagram 1 is an integrated module featuring VS1001k MPEG Layer 3 Audio Decoder IC, which incorporates a Digital to Analog Converter and Headphone Amplifier. The MP3MOD4 provides regulated voltage to the VS1001k via the on-board regulator. The on-board micro controller for ease of development deals with the serial controls for the VS1001k.

The MP3MOD4 receives its input bit stream through a serial input bus. The input stream is decoded and passed to an 18-bit over sampling, multi-bit, sigma-delta Digital to Analog Converter. The decoding is controlled via a serial control bus. In addition to the basic decoding, it is possible to add application specific features, like DSP effects, to the program RAM memory of the VS1001k.

The MP3MOD4 is ideal for rapid prototyping and development when the VS1001k is to be used.

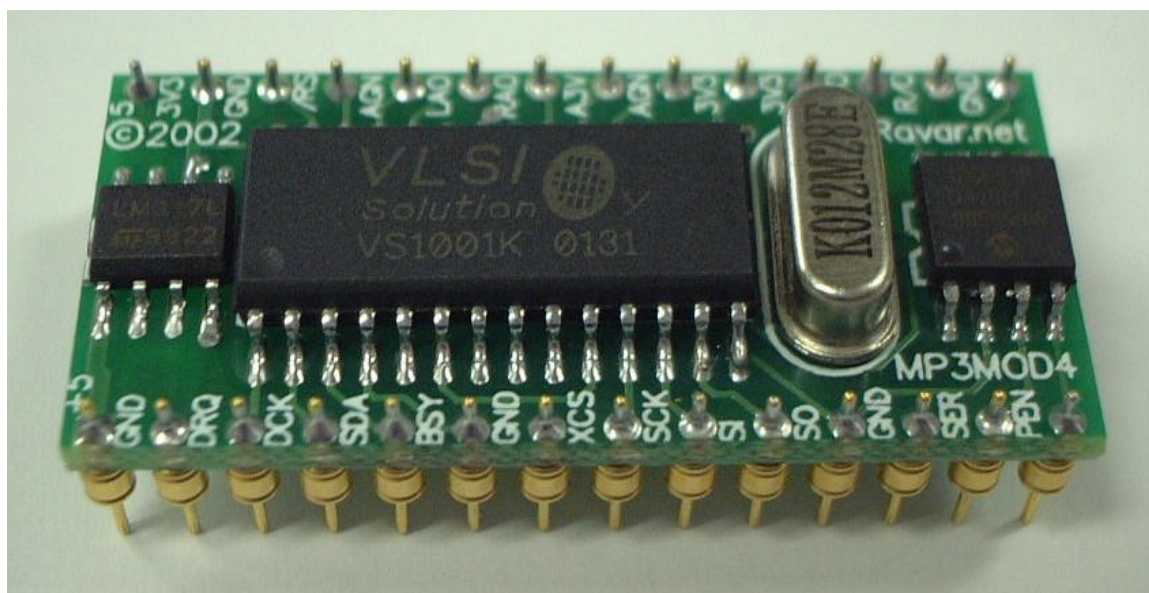

Diagram 1

MODULE FEATURES

- Single MP3 module solution
- Based on VLSI VS1001k MPEG Layer 3 Audio Decoder IC
- On board 3.3V Regulator which provides voltage to the VS1001k and PIC12CE519
- On-board 12.288MHz Crystal
- Controls for the VS1001k are dealt with by the PIC12CE519
- Communication via Asynchronous 1200 Baud Serial Data
- Uses True TTL Serial
- 28-pin Dual In-Line Package Ideal for prototyping
- Fits into a standard 28-pin IC Socket

VS1001k IC FEATURES

- Single Chip MPEG layer 1,2 and 3 audio decoder Solution
- Supports MPEG 1 & 2 for all layers, and layer 3's 2.5 extensions, and all their sample rates and bit rates, in mono or stereo
- PCM Input Mode
- Can be used as a slave co-processor
- Extremely Low power operation
- On-chip high-quality stereo DAC with no phase error between channels
- Supports VBR (variable bit rate) for MP3
- SOIC 28 pin package (10 x 17.5 x 2.5 mm)
- Stereo earphone driver capable of driving a 30 Ω load
- 4kB On-Chip RAM for user code
- Serial control and data interfaces

The internal layout of the VS1001k is shown below.

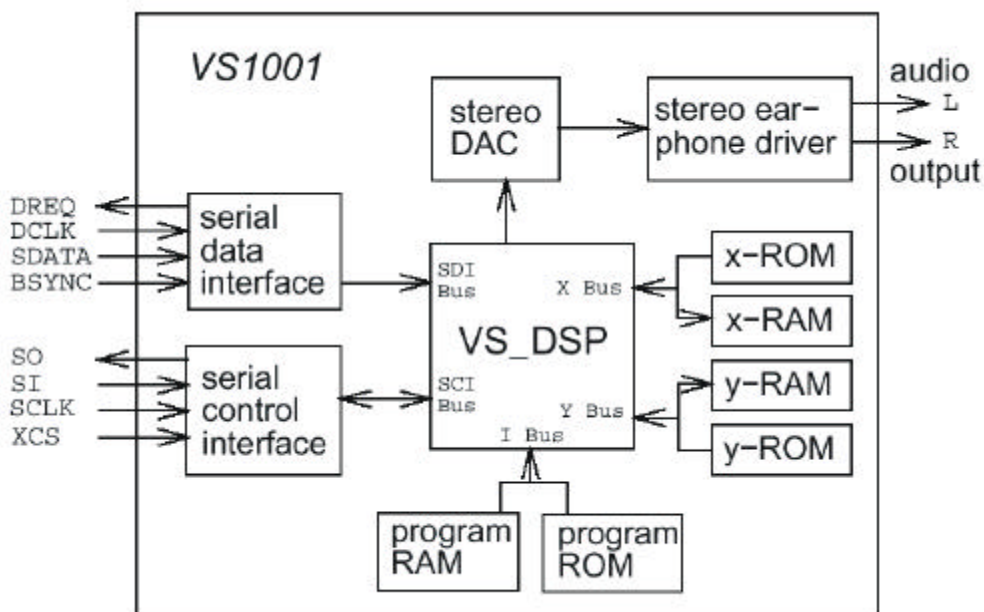

For further information regarding the VLSI VS1001k MPEG AUDIO CODEC IC please refer to the VS1001k Datasheet. This datasheet can be found on the VLSI Oy Solutions website at <http://www.vlsi.fi/>

As mentioned above in module features, the MP3MOD4 is in a 28-pin Dual In-Line Package. This allows the module to fit into a standard 28-pin IC Socket, which makes the module ideal for prototyping and development work. Shown in diagram 2 below is the pin out for the MP3MOD4.

MP3MOD4 PINOUT

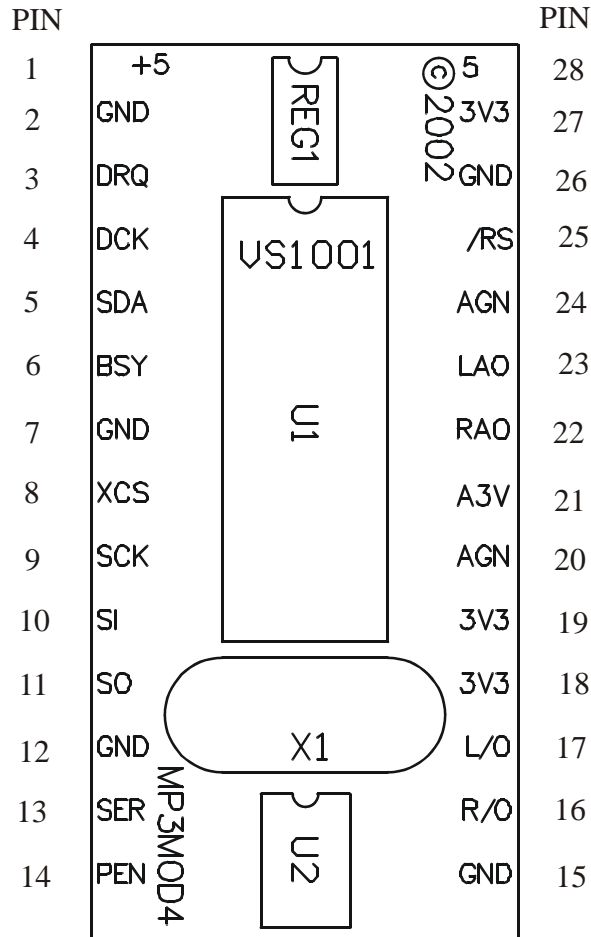

DIAGRAM 2

The following page shows the pin out table for the module.

MP3MOD4 PINOUT TABLE

PIN #	SIGNAL	TYPE	DESCRIPTION
1	+5	PWR	Device - +4.4 volt to +5.25 volt Power Supply Pin
2	GND	GND	Device – Ground Supply Pin
3	DRQ	IN	Data request, Input Bus
4	DCK	I/O	Serial Input data bus clock
5	SDA	IN	Serial Data Input
6	BSY	IN	Byte synchronization signal
7	GND	GND	Device – Ground Supply Pin
8	XCS	IN	Chip select input (active low)
9	SCK	IN	Clock for serial bus
10	SI	IN	Serial Input
11	SO	OUT	Serial Output
12	GND	GND	Device – Ground Supply Pin
13	SER	I/O	True TTL asynchronous serial data 1200 baud
14	PEN	IN	PIC Enable tie to GND to disable the onboard control processor
15	+5	PWR	Device - +4.4 volt to +5.25 volt Power Supply Pin
16	3V3	PWR	Regulated 3.3V Power Supply Pin
17	GND	GND	Device – Ground Supply Pin
18	/RS	IN	Active low asynchronous reset
19	AGN	GND	Analog Ground Supply Pin (VS1001k)
20	LAO	OUT	Left Channel Output
21	RAO	OUT	Right Channel Output
22	A3V	PWR	Analog Power Supply Pin (VS1001k)
23	AGN	GND	Analog Ground Supply Pin (VS1001k)
24	3V3	PWR	Regulated 3.3V Power Supply Pin
25	3V3	PWR	Regulated 3.3V Power Supply Pin
26	L/O	OUT	Left Channel Output through filtering Capacitor
27	R/O	OUT	Right Channel Output through filtering Capacitor
28	GND	GND	Device – Ground Supply Pin

The following page shows the schematic for the MP3MOD4.

MP3MOD 4 SCHEMATIC

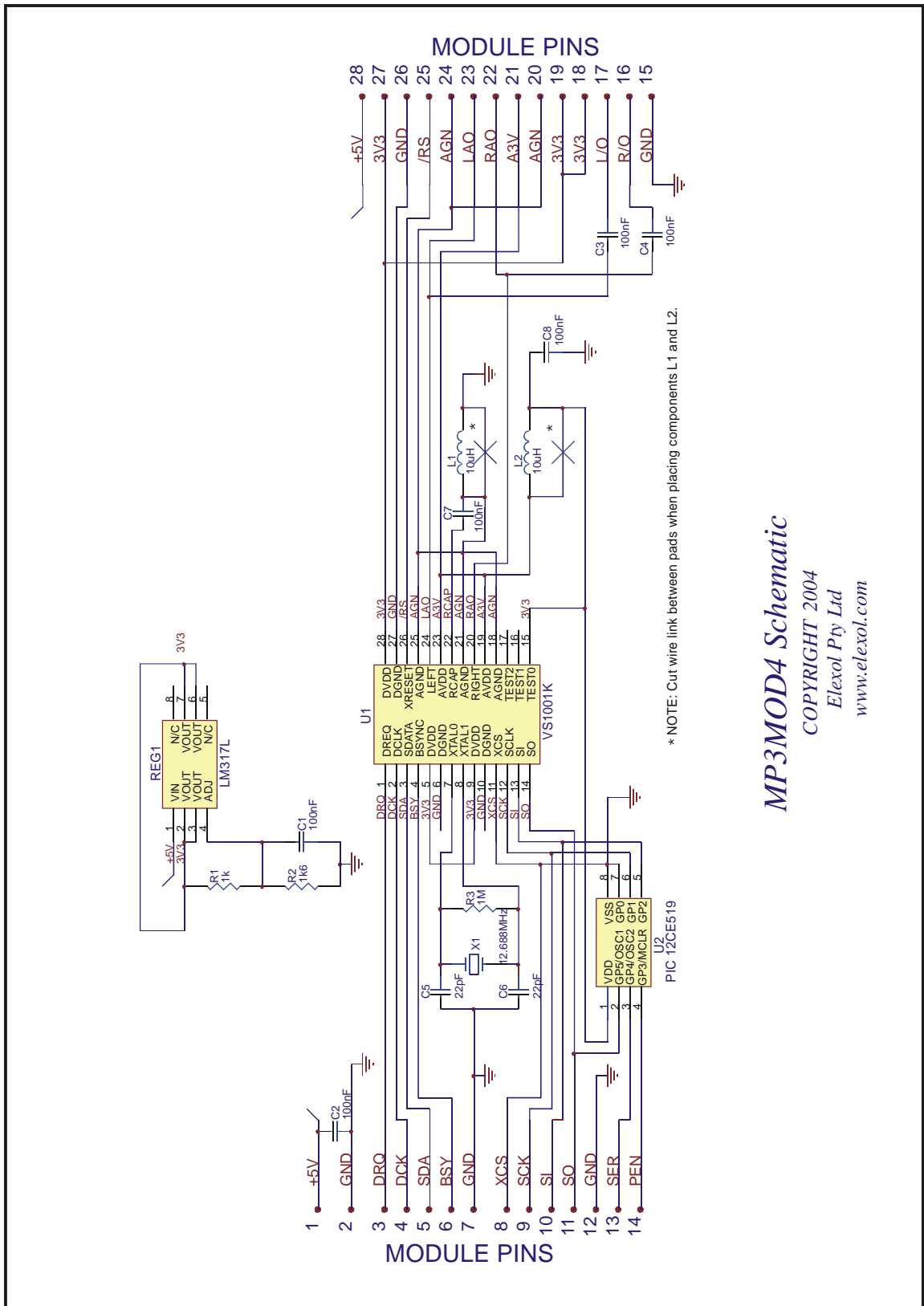

MP3MOD4 Schematic

COPYRIGHT 2004

Elexol Pty Ltd

www.elexol.com

Command Set

Commands are transmitted to the MP3MOD4 via asynchronous 1200 baud serial. The serial data stream is true TTL. Shown below is a table listing the various commands, which can be sent to the MP3MOD4.

Commands Set to run the MP3MOD4

COMMAND	DATA	FUNCTION
0xFF	-	Software Reset MP3 Chip
0xFE	2 Byte Mode	Write Mode Register of VS1001k
0xFD	2 Byte Volume	Write Volume Register of VS1001k
0xFC	Register, 2 Byte Data	Write to VS1001k
0xFB	-	Increase Volume (Both Channels)
0xFA	-	Decrease Volume (Both Channels)
0xF9	1 Byte Volume	Set Volume both Channels same
0xF8	-	Saves volume into EEPROM
0xF7	-	Saves Mode into EEPROM

Application Notes

The sample application shows how a MP3MOD4 can be used in conjunction with a specially programmed USB I/O24. The basic setup is shown in Diagram 3 below, while the following page shows the schematic for the setup.

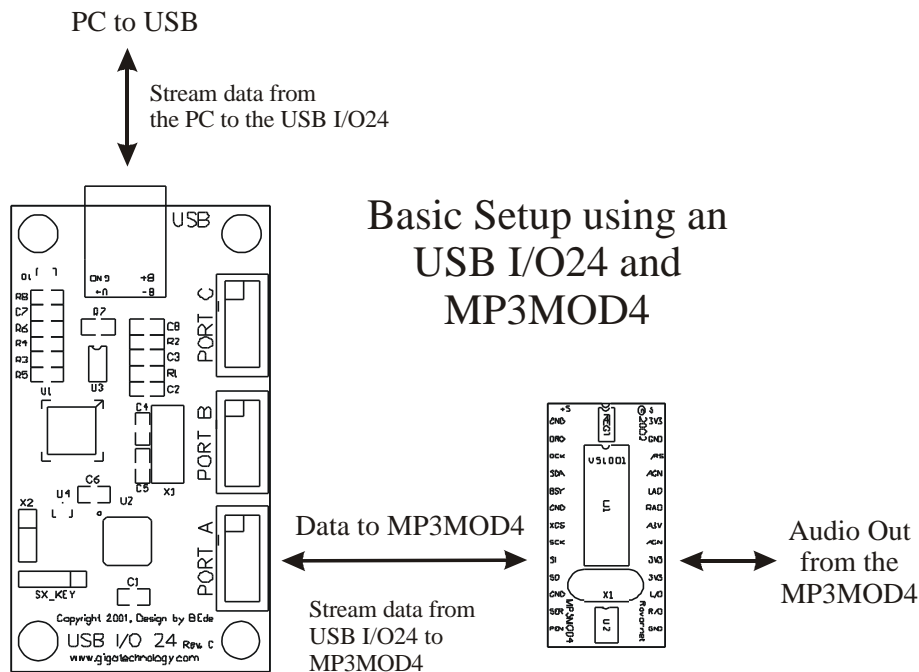

Absolute Maximum Ratings

Parameter	Symbol	Min	Max	Unit
Positive Supply	+5 or 5	4.5*	15	V
Analog Positive Supply	AV3	2.8	3.6	V
Digital Positive Supply	3V3	2.8	3.6	V
Current at Any Digital Output			? 50	mA
Voltage at Any Digital Input		GND – 1.0	3V3 + 1.0	V
Operating Temperature		-30	+85	?C
Functional Operating Temperature		-40	+95	?C
Storage Temperature		-65	+150	?C

* If +5 or 5 is below 4.5V, distortion performance may be compromised

Recommended Operating Conditions

Parameter	Symbol	Min	Typ	Max	Unit
Analog and Digital Ground	AGN GND		0.0		V
Positive Supply	+5	4.5	5	15	V
Positive Analog	AV3	2.8	3.3	3.6	V
Positive Digital	3V3	2.8	3.3	3.6	
Ambient Operating Temperature		-30		+85	°C

Digital Characteristics

Parameter	Symbol	Min	Typ	Max	Unit
High-Level Input Voltage		2.31			V
Low Level Input Voltage				0.99	V
High Level Output Voltage at $I_O = -2.0\text{mA}$		2.31			V
Low Level Output Voltage at $I_O = 2.0\text{mA}$				0.99	V
Input Leakage Current				1.0	?A

Analog Characteristics

Parameter	Symbol	Min	Typ	Max	Unit
DAC Resolution			16		Bits
Total Harmonic Distortion	THD		0.1	0.2	%
Dynamic Range (DAC unmatd, A-weighted)	IDR		90		dB
S/N Ratio (full scale signal)	SNR	70	87		dB
Interchannel Isolation			50	75	dB
Interchannel Gain Mismatch		-0.5		0.5	dB
Frequency Response		-0.1		0.1	dB
Frequency Response, AVDD = 2.8V		-0.3		0.3	dB
Full Scale Output Voltage (Peak to Peak)		1.4	1.8 *	2.0	V _{pp}
Deviation from Linear Phase				5	°
Out of Band Energy			-60		dB
Out of Band Energy with Analog Filter			-90		dB
Analog Output Load Resistance, no ground buffer	AOLR1	16	30 **		Ω
Analog Output Load resistance, ground buffer	AOLR2	16	100 **		Ω
Analog Output Load Capacitance				1000	pF

* 3.6 Volts can be achieved with +-to-+ wiring for mono difference sound

** AOLR1/2 may be much lower, but typical distortion performance may be compromised

DAC Interpolation Filter Characteristics

Parameter	Symbol	Min	Typ	Max	Unit
Passband (to -3 dB corner)		0		0.459F _s	Hz
Passband (Ripple Spec)		0		0.420F _s	Hz
Passband Ripple				±0.056	dB
Transition Band		0.420F _s		0.580F _s	Hz
Stop Band		0.580F _s			Hz
Stop Band Rejection		90			dB
Group Delay			15/F _s		S
-3 dB Bandwidth		300			kHz
Passband Response at 20kHz		-0.05			dB

Technical Support and Further Information

For any questions relating to the MP3MOD4 please contact us by Email, Fax or Phone.

Email: support@elexol.com

Fax: +61 755 743988

Ph: +61 755 743833

Elexol Pty Ltd
Level 2
Commerce Centre
146 Bundall Road, Bundall
Queensland 4217
Australia

Elexol Pty Ltd
PO Box 5972
GCMC
Queensland 9726
Australia

Product Use Limitations, Warranty and Quality Statement.

The MP3MOD4 should not be used in any situation where it's failure or failure of the PC or software controlling it could cause human injury or severe damage to equipment. This device is not designed for or intended to be used in any life critical application.

The MP3MOD4 is warranted to be free from manufacture defects for a period of 12 months from the date purchase.

Subjecting the device to conditions beyond the Absolute Maximum Ratings listed above will invalidate this warranty.

The MP3MOD4 is a static sensitive device, anti static procedures should be used in the handling of this device.

All MP3MOD4 units are extensively tested at time of manufacture to be free of defects.

Elexol is committed to providing products of the highest quality. Should you experience any product quality issues with this product please contact our quality assurance manager at the above address.

Disclaimer.

This product and its documentation are provided as-is and no warranty is made or implied as to their suitability for any particular purpose.

Elexol Pty Ltd will not accept any claim for damages arising from the use of this product or documentation.

This document provides information on our products and all efforts are made to ensure the accuracy of the information contained within. The specifications of the product are subject to change and continual improvement.